



for a greener tomorrow



APPLICATION SOLUTIONS

Labeling Machine

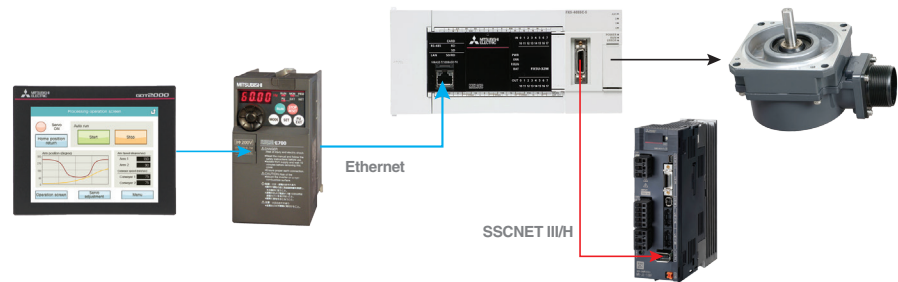
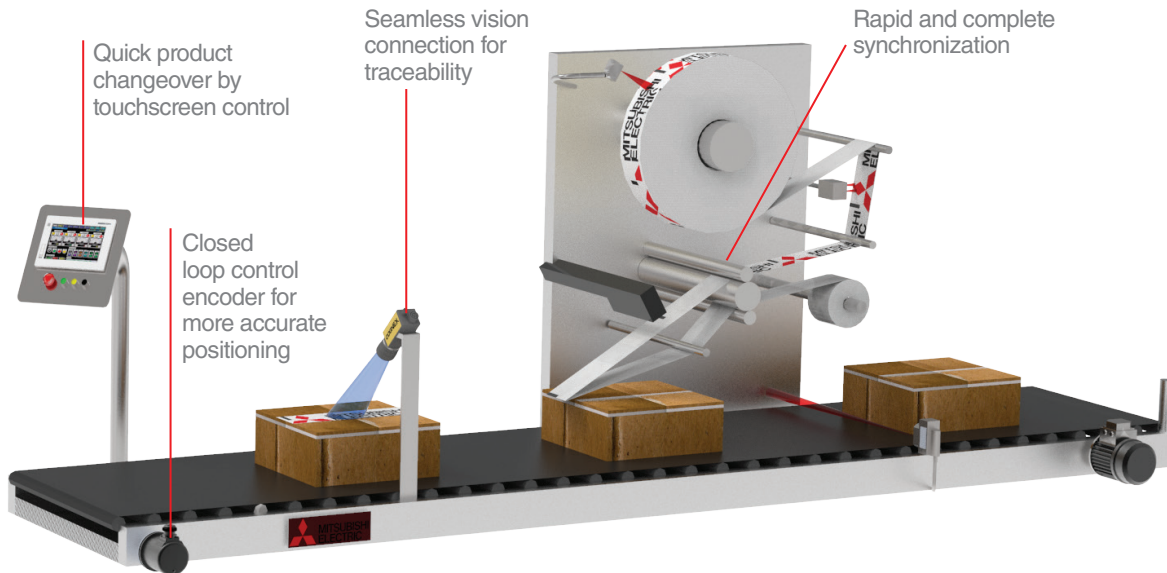

TYPICAL USE CASES

Labeling technology is applied to attach labels in a variety of applications including:

- Food and beverage
- Pharmaceutical
- Material handling
- Mailing
- Bottles and cans
- Stationery goods

OVERVIEW

Labeling is essential to a company's brand. End users demand labeling machines that deliver high output, consistency, and reliability to ensure the quality of their product, without slowing down production. High speed registration and encoder following is used in order to accurately position labels on various formats including bags, bottles, boxes, and trays. iQ-F Series compact controllers and integrated motion control combine with the VFD for the conveyor and servo drives for labeling on one network, providing a smart solution that improves OEE and assures hassle-free maintenance.

Labeling Machine

SOLUTION SET

PLC: iQ-F Series

Motion Control: FX5 Simple Motion

HMI: GT21 Series

VFD: FR-E700 Series

Servo Amplifier: MR-JE Series

KEY PRODUCT ATTRIBUTES

- Seamless connectivity
- Highly integrated PLC, HMI, motion controls
- Cam profile generation
- Deterministic and synchronized motion communication

THE BOTTOM LINE

- Reduce development time
 - User-friendly HMI screens monitor servo amplifier alarms
 - Native communication to Cognex camera
 - Create cam profile with generator tool
 - One software design environment for PLC and motion
- Prevent untimely shutdowns
 - Real-time machine analysis and diagnostics
 - Monitor component health
 - Backup/restore PLC program from SD card
- Full synchronous performance in multi-axis system
 - Highly responsive SSCNET III/H 0.222ms cycle time
 - Complete deterministic and synchronized communication
- Handles multiple package formats
 - Touchscreen recipe control
- Improve quality
 - Verify consistency with connectivity to vision system
- Comply with reporting regulations
 - Collect scanned barcode information
 - Transfer data to upper level IT network

MITSUBISHI ELECTRIC AUTOMATION, INC.

500 Corporate Woods Parkway, Vernon Hills, IL 60061
Ph 847.478.2100 • Fx 847.478.2253

us.MitsubishiElectric.com/fa/en

December 2018 • ©2018, Mitsubishi Electric Automation, Inc.
Specifications subject to change without notice. • All rights reserved

L-VH-07013